

MORGAN PRODUCTS

PNEUMATIC CHEMICAL PUMPS FOR THE GAS AND OIL INDUSTRIES

MODEL D15-316-TR2

AIR ACTUATED POSITIVE DISPLACEMENT PUMP

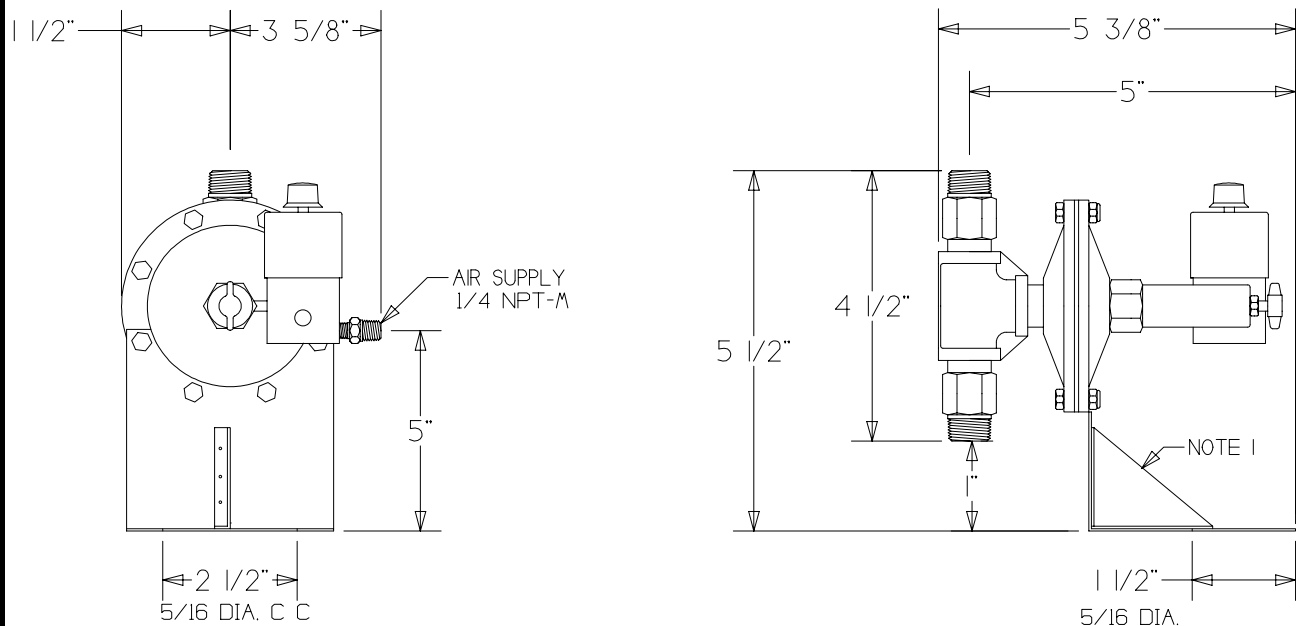

Note:

Mounting Bracket may be removed

MODEL (WITH TIMER)	DISPLACEMENT	PUMP RATIO	DIAPHRAGM SIZE in. - cm.	CONNECTIONS ALL NPT INPUT / OUTPUT	MAXIMUM DISCHARGE PSI - BAR	OUTPUT PER HOUR GAL. / LTS.
D15-316-TR2	6.6 cc	1:1	1.5 / 3.8	1/4 - M / 1/4 - F	125 - 8.6	.5 - 5.2 / 2 - 20

MORGAN PRODUCTS INC. 28103 Ave. Stanford / Valencia, CA 91355

(661) 257-3022 - (800) 421-8910 - FAX (661) 257-3385

www.morganproducts.com - E-Mail info@morganproducts.com

MORGAN PRODUCTS

PNEUMATIC CHEMICAL PUMPS FOR THE GAS AND OIL INDUSTRIES

Parts List Model D10-316, D15-316, D25-316 & D40-316

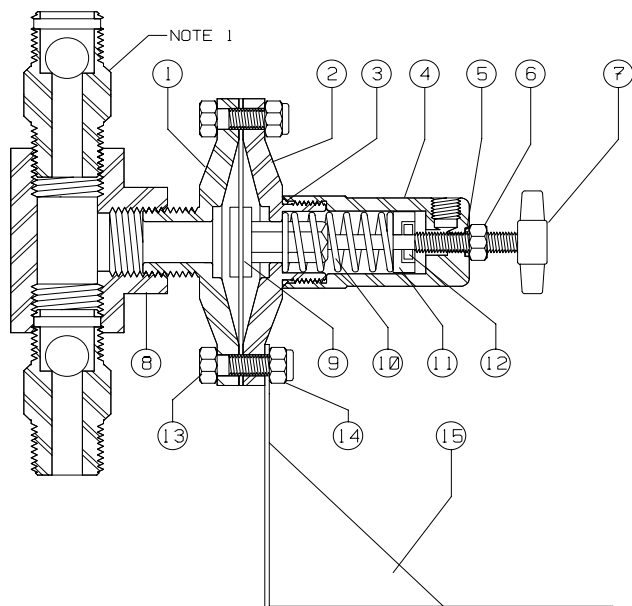

No	Name	D10	D15	D25	D40
1	Pressure Chamber	D10-316-1	D15-316-1	D25-316-1	D40-316-1
2	Drive Chamber	D10-2	D15-2	D25-2	D40-2
3	O-Ring Seal	50-21*		100-21*	
4	Spring Housing	D15-3		D25-3	D40-3
5	O-Ring Seal	100-11*			
6	Locknut	50-2			
7	Stroke Adjuster	50-1			
8	Check Valve Tee	D15-11		D25-11	D40-11
9	Diaphragm Assembly	D10-7*	D15-7*	D25-7*	D40-7*
10	Return Spring	50-13*		D25-6*	250-13*
11	Spring Retainer	D15-5		D25-5	
12	Retainer Pin	D15-4		D25-4	
13	Chamber Bolt	D15-316-10+		D40-316-10+	
14	Chamber Locknut	D15-9+		D40-9+	
15	Stand	D10-13	D15-13	D25-13	D40-13
	Repair Kit	D10-50	D15-50	D25-50	D40-50

NOTE 1:

D10 & D15 Check Valve MM4-316 (2 Required)
 D25 Check Valve MM8-316 (2 Required)
 D40 Check Valve MM12-316 (2 Required)

* = Included in Repair Kit

+ = 6 ea. Required on D10, D15 & D25

8 ea. Required on D40

Set-Up and Operation

1. Discard all red protective closures.
2. Connect the suction check valve (bottom) to the chemical source.
3. Connect the discharge check valve (top) to your process line.
4. Connect a regulated air/gas supply (150 psi maximum) to the timing relay.
5. Set the air/gas supply 10-15 psi higher than process line pressure.
6. Set cycle rate on the TR2 timing relay to get flow rate required. (see chart)

CAUTION: Do not use this pump with chemicals that become hazardous when aerated.

CAUTION: Check Valves will not stop flow of chemical supply. Install a shut off valve between pump and chemical source.

MODEL NO.	D10-316	D15-316	D25-316	D40-316
Volume Per Stroke	.3 oz - .8cc	.2 oz - 6cc	.7oz - 21cc	1.7 oz - 51cc
Maximum Volume Per Day	15 ga. - 58 liters	125 ga. - 473 liters	400 ga. - 1514 liters	720 ga. - 2725 liters
Maximum Stroke Rate	50 SPM			
Maximum Discharge Pressure	150 PSI		10.34 BAR	
Diaphragm Size	1 in. - 2.5 cm.	1.5 in - 3.8 cm	2.5 in - 6.35 cm	4 in - 10.16 cm
Diaphragm Material	Teflon			
Pump Material	316 SS			
Suction Size	1/4 NPT (M)	1/4 NPT (M)	1/2 NPT (M)	3/4 NPT (M)
Discharge Size	1/4 NPT (M)	1/4 NPT (M)	1/2 NPT (M)	3/4 NPT (M)

MORGAN PRODUCTS INC. 28103 Ave. Stanford / Valencia, CA 91355

(661) 257-3022 - (800) 421-8910 - FAX (661) 257-3385

www.morganproducts.com - E-Mail info@morganproducts.com